

END ELEVATION

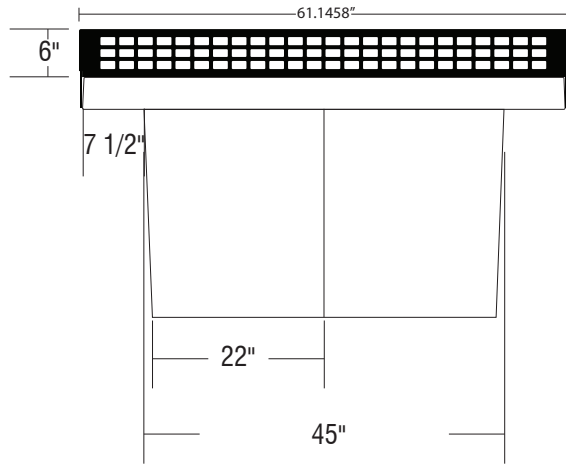
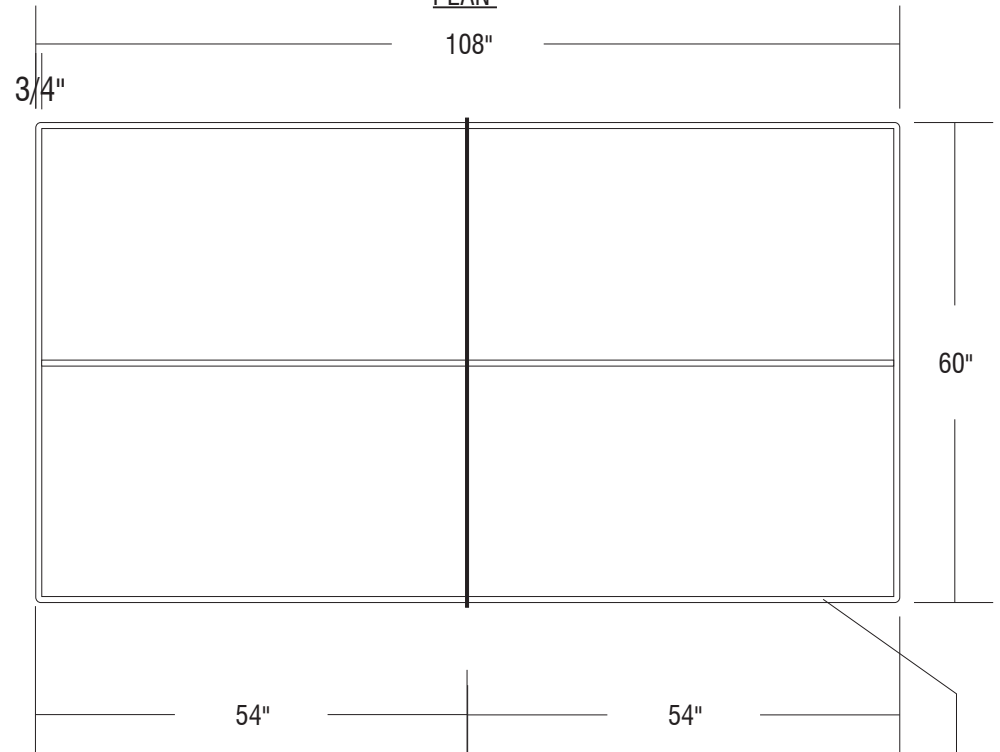

TABLE NET TO BE 3/8" STEEL LASER CUT WITH ARTWORK AS SHOWN. ATTACHED TO TABLE VIA WELDED SIDE BRACKETS BOLTED TO CAST IN INSERTS IN TABLE SIDES

2"x1" rectangles cut into net to simulate real net  
 Will be single layer, being able to see through rectangles in net  
 Powdercoated black

*\*Custom text available, read correctly both sides*

PLAN



3/4" FIELD LINES PAINTED ON TABLE TOP - WHITE

ELEVATION

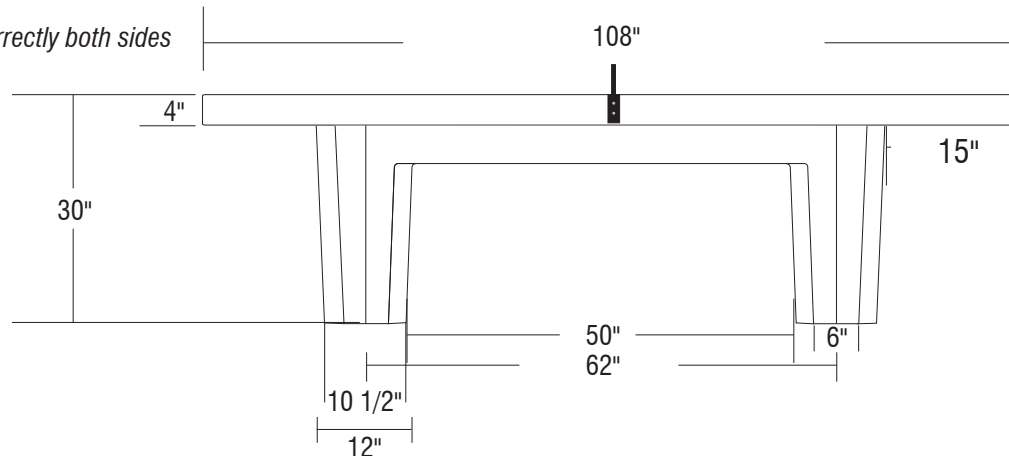

NOTES:

1. Concrete mix design to include a mixture of Portland Cement, water, coarse and fine aggregates, pure mineral oxide coloring agents (when applicable) to yield a minimum compressive strength of 5000 psi.
2. Final product shall be reinforced with #4 and #5 rebar grid.
3. Product is cast in 1-piece with no assembly required.
4. Hairline cracks may develop over time. These are not structural failures, but inherent characteristics of the material itself.
5. Air pockets are a common occurrence in precast products. The frequency and size of air pockets are variable and to be expected, especially on vertical surfaces.
6. Concrete corners and edges will chip if not handled according to guidelines. Patch kits are available but may or may not blend and can be variable.
7. There is a level of care and maintenance associated with your product and is the responsibility of the end user. Choosing the right sealer can help minimize those costs.

WEIGHT: 4500 LBS  
 TEXTURE:  
 COLOR:  
 SEALER:

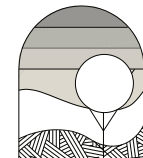

**OUTDOOR CREATIONS INC.**  
 2270 Barney Street  
 Anderson, CA 96007  
 (530) 365-6106  
 FAX (530) 365-5129