

MODEL #516 - (3) COMPARTMENT CONCRETE TRASH/RECYCLING RECEPTACLE, **DUAL DEPOSIT**

OUTDOOR CREATIONS, INC.
CUSTOMER APPROVAL x _____

SCALE: 1" = 24"
DRAWN BY: MNC

SIDE ELEVATION-Trash

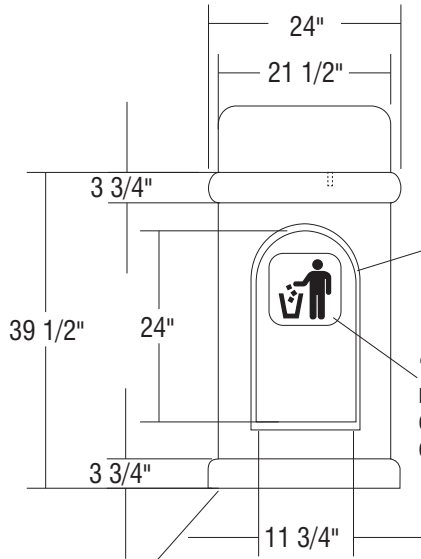

Steel Door
Powder Coated Std.
Color "Black"
GR1372-BK05
on trash side of unit
with "Landfill" decal
applied, white vinyl

3/4" chamfer around
3/4" deep inlay area

"Trash" logo cast in full
relief and painted "Black"
on "White" Background
of trash side of receptacle

Recommended to secure trash
receptacle to concrete
slab with construction epoxy.

FRONT ELEVATION

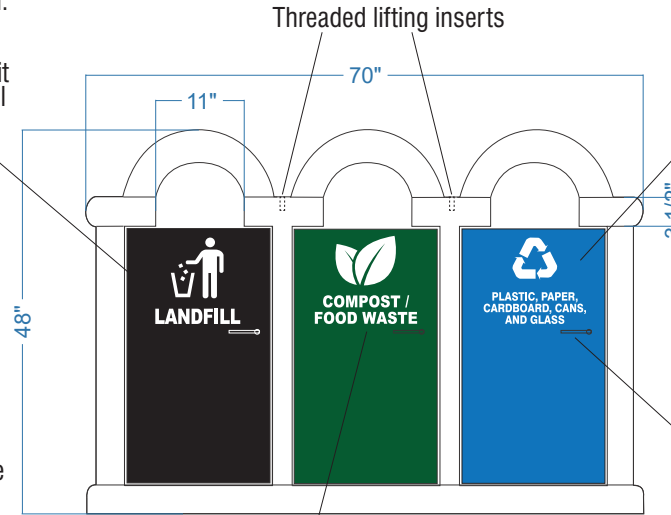

Steel Door, powdercoated
Recycle Green GR1372-GN03
in middle of unit with "Compost"
decal applied, white vinyl

Steel Door
Powder Coated
Color "Recycle Blue"
GR1372-BL01 on
Recycle side of unit
with "Recycle" decal
applied, white vinyl

All doors to have
lockable handles,
no lock provided

SIDE ELEVATION-Recycle

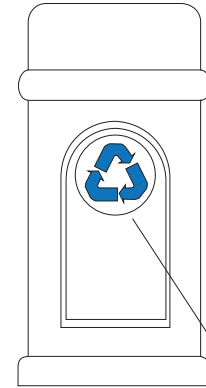

10" dia "Recycle" logo cast in full
relief and painted "Recycle Blue"
on "White" Background of
recycle side of receptacle

PLAN VIEW

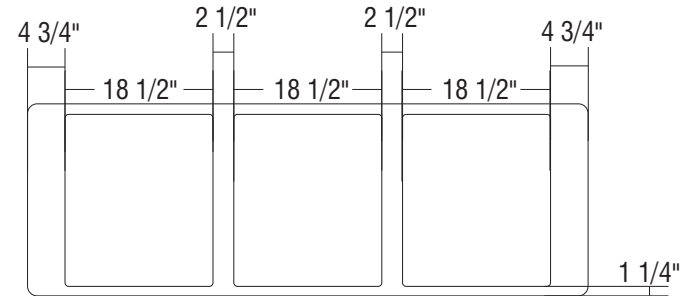

REAR ELEVATION

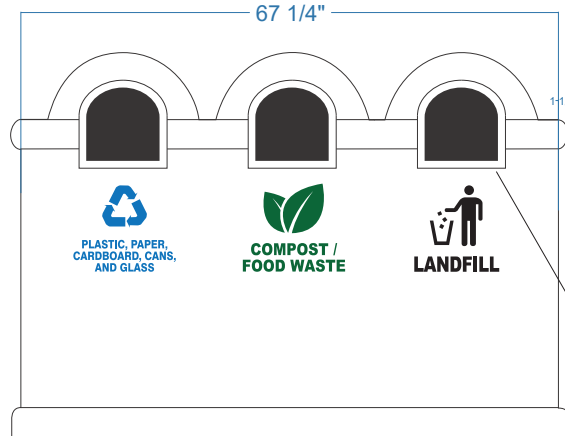

(3) 11" x 11" openings on back of receptacle
Inside of opening is 8 1/2" x 8 1/2"

NOTES:

1. Concrete mix design to include a mixture of Portland Cement, water, coarse and fine aggregates, pure mineral oxide coloring agents (when applicable) to yield a minimum compressive strength of 5000 psi.
2. Final product shall be reinforced with #4 and #5 rebar grid.
3. Product is cast in 1-piece with no assembly required.
4. Hairline cracks may develop over time. These are not structural failures, but inherent characteristics of the material itself.
5. Air pockets are a common occurrence in precast products. The frequency and size of air pockets are variable and to be expected, especially on vertical surfaces.
6. Concrete corners and edges will chip if not handled according to guidelines. Patch kits are available but may or may not blend and can be variable.
7. There is a level of care and maintenance associated with your product and is the responsibility of the end user. Choosing the right sealer can help minimize those costs.

(3) engravings, matching decals on doors
Landfill: Painted black 11" x 10 1/2"
Compost: Painted recycle green 12 3/4" x 11"
Recycle: Painted recycle blue 12 3/4" x 11"

*Unit includes (3) Plastic Liners: SQT29

WEIGHT: 3250 LBS
TEXTURE:
COLOR:
SEALER:



**OUTDOOR
CREATIONS
INC.**
2270 Barney Street
Anderson, CA 96007
(530) 365-6106
FAX (530) 365-5129